

## BV12SA-GAS-2425NG-PN10 - Wormwielkast DVGW **belven**<sup>®</sup> gekeurd

Lug type vlinderklep, ATEX, te monteren tussen flenzen PN10, met wormwielkast, DVGW Gas gekeurd volgens EN 13774:2013  
Norm Bouwlengte: EN 558-1 Tabel 1 serie 20

Met NBR-GAS zitting volgens EN 685



Artikelnummer	Belven Ref.
12SAG2044NG30200	BV12SA-GAS-2425NG-PN10-DN200 - GEARBOX
12SAG2044NG30250	BV12SA-GAS-2425NG-PN10-DN250 - GEARBOX
12SAG2044NG30300	BV12SA-GAS-2425NG-PN10-DN300 - GEARBOX

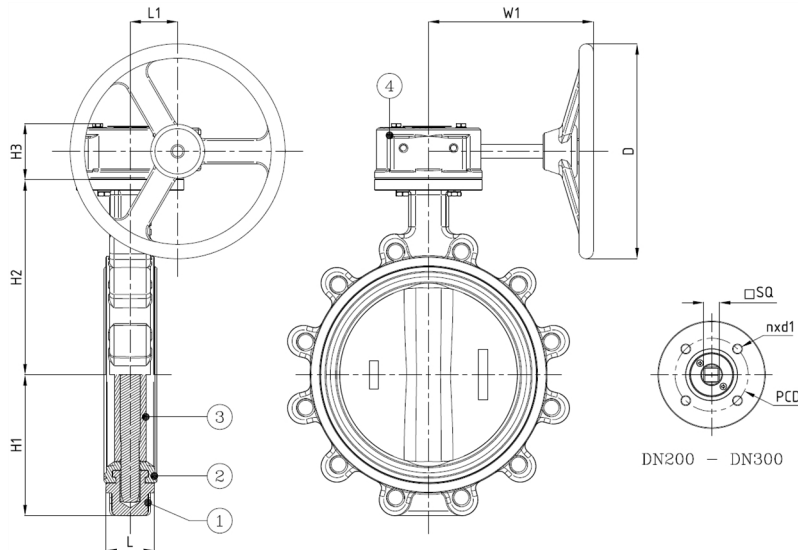

DN/Inch	L	H1	H2	H3	H4	L1	SQ	ISO	PCD	n x d1	D	W1	Drukl.	Gewicht(kg)
DN200 (8")	60	165	243,5	80,5	45	63	17	F10	102	4 x d12	300	237	PN10	26,20
DN250 (10")	68	202	273	80,5	45	63	22	F10	102	4 x d12	300	237	PN10	38,00
DN300 (12")	78	235	311	80,5	45	78	27	F12	125	4 x d14	300	225	PN10	55,70

Item 1	Item 2	Item 3	Item 4
<b>Materiaal Huis</b>	<b>Materiaal Zitting</b>	<b>Materiaal Klepblad</b>	<b>Materiaal Bediening</b>
Nodulair gietijzer : GGG40 + Epoxy coating	NBR-GAS	Vernikkeld : GGG40 + Ni	Gietijzer